

Complete range on
Swiss cut solutions



SAL
Swiss Automatic Lathes



MAIN FEATURES - Características principais | Características principales

Palbit inserts are specially developed to suit the cutting conditions and swiss automatic lathes. Our inserts are made of micro grain carbide which results in maximum strength when considering hardness and wear resistance. All cutting edges are fully ground and exceptionally sharp. Furthermore, we have applied our latest PVD coating on these specific cutting geometries, to achieve an excellent tool life with Palbit inserts.

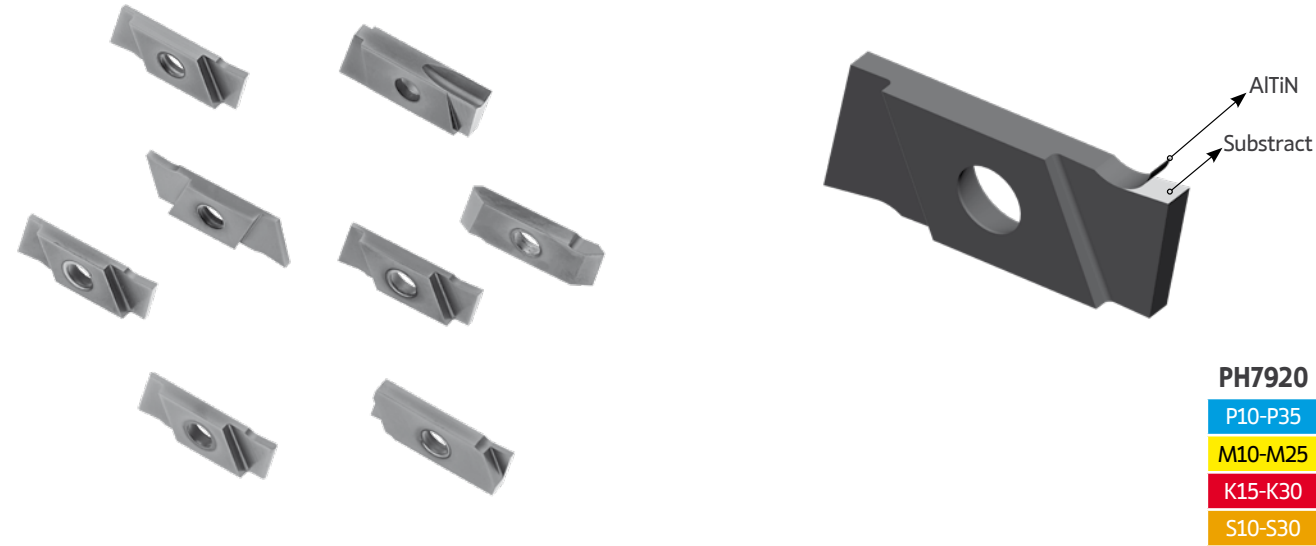

MULTIPLE INSERTS - Múltiplas pastilhas | Multiplas plaquitas

Right toolholders and inserts style show

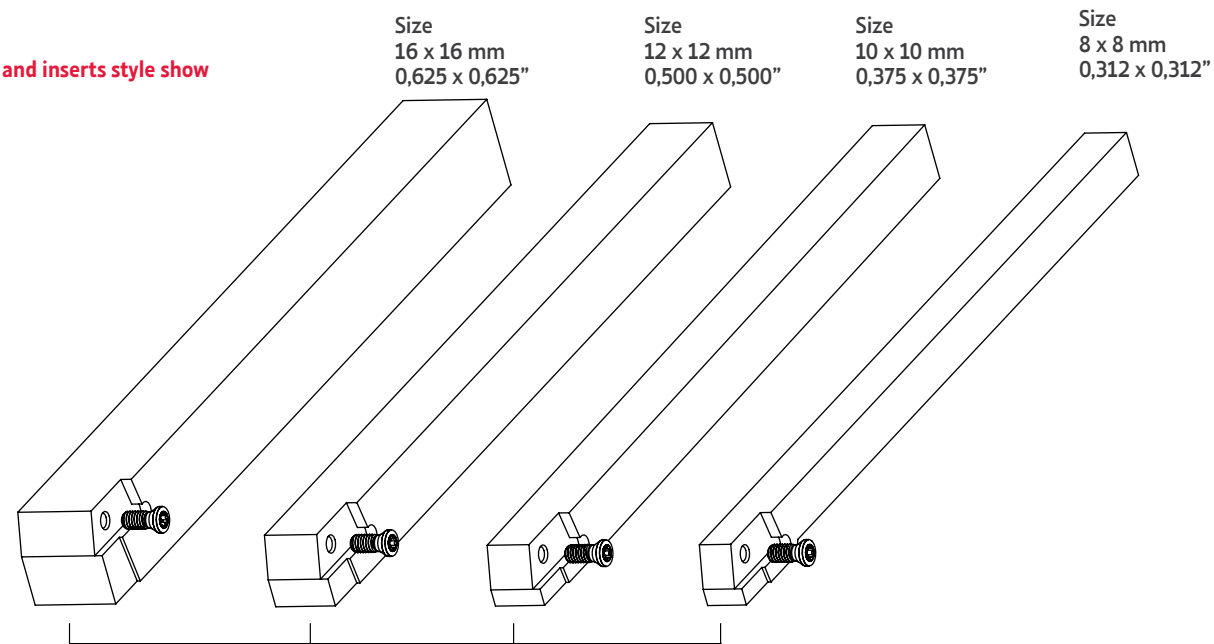

Select the toolholder and the insert. All inserts are compatible with all toolholders off the same side.

Selecione a medida do ferro de torno e da pastilha que deseja. Todas as pastilhas são compatíveis com todos os suportes do mesmo lado.
 Seleccione la dimension de la herramienta y de la plaquita que desea. Todas las plaquitas son compatibles con su herramienta del mismo lado.

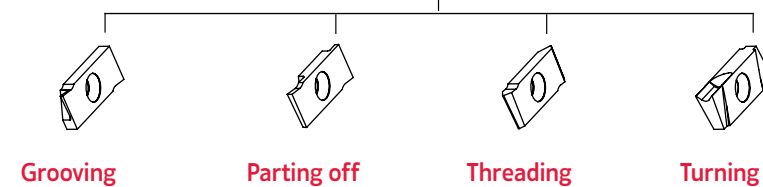

MAIN APPLICATIONS | Aplicações principais | Aplicaciones principales

INSERTS

4 Different operations:

- Turning
- Parting off
- Grooving
- Threading

TOOLHOLDERS

Dimensions:

- 08x08mm
- 10x10mm
- 12x12mm
- 16x16mm

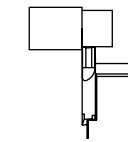

Turning

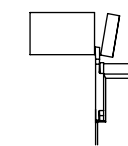
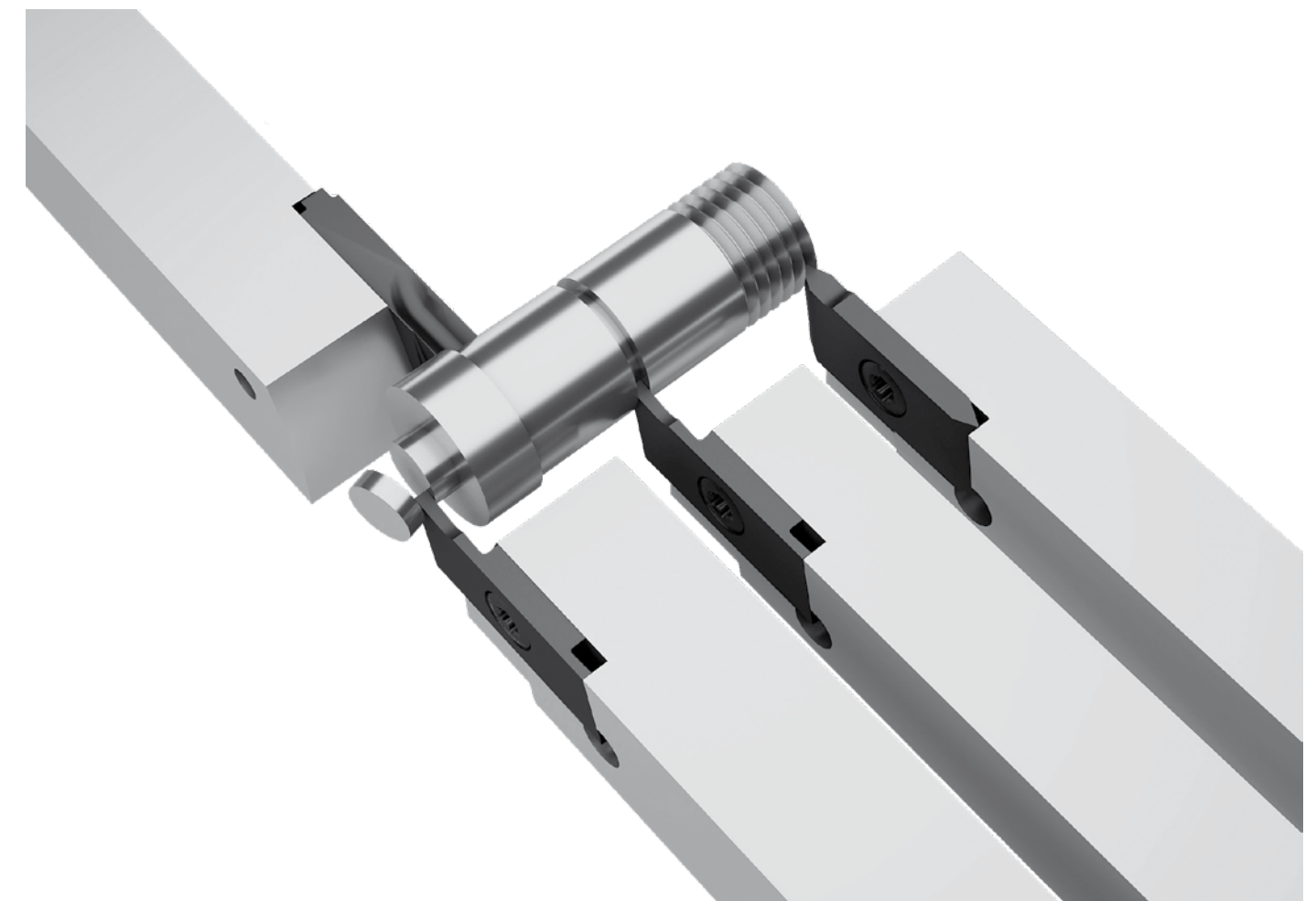

Parting off

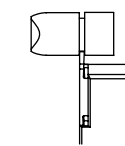

Grooving

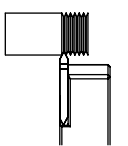

Threading

INSERTS CODE KEY - Chave de codificação para pastilhas | Llave de codificación de plaquitas

Grooving Inserts										
SAL	25	G	050	R						GS
1	2	5	6	8	-					11
Parting Off Inserts										
SAL	11	P	100	R	N					P07
1	3	5	6	8	9	-				11
Threading Inserts										
SAL	100	H	010	R	60					PT
1	4	5	7	8	10	-				11
Turning Inserts										
SAL	60	T	300	R						TP
1	2	5	6	8	-					11

1 - Product line
SAL - Swiss Automatic Lathes Line
2 - Maximum depth of cut (Turning and Grooving inserts)
25 - 2,5mm 60 - 6,0mm
3 - Maximum Cutting Diameter (Parting Off Inserts)
11 - 11,0mm 13 - 13,0mm

4 - Center distance (Threading Inserts)			
050 - 0,5mm 100 - 1,00mm			
5 - Operations type			
G - Grooving	P - Parting off	H - Threading	T - Turning

6 - Cut thickness (Grooving, Parting Off and Turning Inserts)	
050 - 0,50mm 070 - 0,70mm 080 - 0,80mm 090 - 0,90mm 100 - 1,00mm 110 - 1,10mm 130 - 1,30mm 150 - 1,50mm 160 - 1,60mm 185 - 1,85mm 200 - 2,00 mm 300 - 3,00 mm	
7 - Corner radius (Threading Inserts)	
005 - 0,05mm 010 - 0,10mm 012 - 0,12mm	
8 - Insert / toolholder side	
L - Left hand	R - Right hand

9 - Front angle (Parting off)		
N - Neutral	R - Right	L - Left
10 - Angle (Threading Inserts)		
55 - 55° 60 - 60°		
11 - Chip Breaker (Turning, Grooving, Parting Off and Threading Inserts)		
Turning	TP - Turning steel	
Grooving	GS - Square Grooving GR - Round Grooving	
Parting Off	P00 - Front angle 0° P07 - Front angle 7°	
Threading	PT - Partial Profile	

TOOLHOLDERS CODE KEY - Chave de codificação para suportes | Llave de codificación de herramienta

For conventional Toolholders (Metric)										
SAL	H	E	R			08	08		M	07
1	2	3	4	-		5	6		7	8
For Conventional Toolholders (Imperial)										
SAL	H	E	L			07	05			
1	2	3	4	-		8	9			

1 - Product line
SAL - Swiss Automatic Lathes Line
2 - Tool type
H - Holder
3 - Internal or External
E - External

4 - Insert / toolholder side		5 - Shank height (Metric)	6 - Shank width (Metric)
L - Left hand	R - Right hand	Metric	Metric
		08 - 8 mm	08 - 8 mm
		10 - 10 mm	10 - 10 mm
		12 - 12 mm	12 - 12 mm
		16 - 16 mm	16 - 16 mm

7 - Shank height (Metric or Imperial)	
L - 140 mm	
M - 150 mm	

8 - Insert cutting edge length (mm)	9 - Shank height (Imperial)
07 - 7,0 mm	Imperial
	05 - 5/16" x 5/16"
	06 - 3/8" x 3/8"
	08 - 1/2" x 1/2"
	10 - 5/8" x 5/8"

EXTERNAL TOOLHOLDERS | Suportes exteriores | herramientas de tronzado exterior

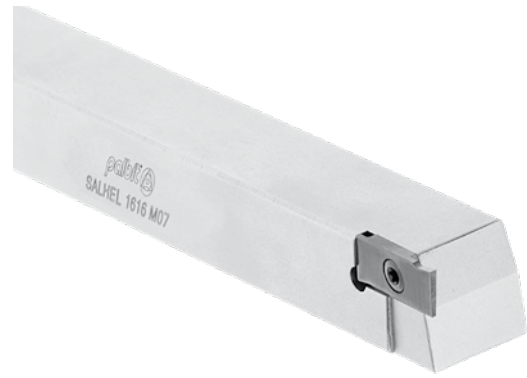

Left hand style show



Order code Código	Reference Referência Referencia	Dimensions Dimensões Dimensiones (mm)					* Insert	Screw	Wrench	Stock
		h	b	H	L1	s				
Metric										
213023600	SALHEL 0808 M07	8,00	8,00	8,00	150,00	8,00	SAL...L	P0300900	XT 08	☺
213023700	SALHEL 1010 M07	10,00	10,00	10,00	150,00	10,00	SAL...L	P0300900	XT 08	☺
213023800	SALHEL 1212 M07	12,00	12,00	12,00	150,00	12,00	SAL...L	P0300900	XT 08	☺
213023900	SALHEL 1616 M07	16,00	16,00	16,00	150,00	16,00	SAL...L	P0300900	XT 08	☺
Imperial										
213024700	SALHEL 05-07	0,312	0,312	0,312	6,00	0,312	SAL...L	P0300900	XT 08	☺
213024800	SALHEL 06-07	0,375	0,375	0,375	6,00	0,375	SAL...L	P0300900	XT 08	☺
213024900	SALHEL 08-07	0,500	0,500	0,500	6,00	0,500	SAL...L	P0300900	XT 08	☺
213025000	SALHEL 10-07	0,625	0,625	0,625	6,00	0,625	SAL...L	P0300900	XT 08	☺

☺ Stock item | Itens de stock

* Left insert only fits on left toolholder



Right hand style show

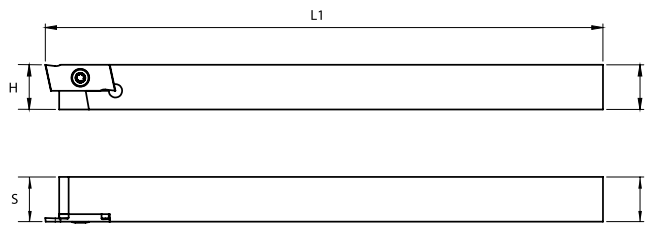

Order code Código	Reference Referência Referencia	Dimensions Dimensões Dimensiones (mm)					* Insert	Screw	Wrench	Stock
		h	b	H	L1	s				
Metric										
213023200	SALHER 0808 M07	8,00	8,00	8,00	150,00	8,00	SAL...R	P0300900	XT 08	☺
213023300	SALHER 1010 M07	10,00	10,00	10,00	150,00	10,00	SAL...R	P0300900	XT 08	☺
213023400	SALHER 1212 M07	12,00	12,00	12,00	150,00	12,00	SAL...R	P0300900	XT 08	☺
213023500	SALHER 1616 M07	16,00	16,00	16,00	150,00	16,00	SAL...R	P0300900	XT 08	☺
Imperial										
213024300	SALHER 05-07	0,312	0,312	0,312	6,00	0,312	SAL...R	P0300900	XT 08	☺
213024400	SALHER 06-07	0,375	0,375	0,375	6,00	0,375	SAL...R	P0300900	XT 08	☺
213024500	SALHER 08-07	0,500	0,500	0,500	6,00	0,500	SAL...R	P0300900	XT 08	☺
213024600	SALHER 10-07	0,625	0,625	0,625	6,00	0,625	SAL...R	P0300900	XT 08	☺

☺ Stock item | Itens de stock

* Right insert only fits on right toolholder

GS SERIES | Inserts | Pastilhas | Plaquetas



Right hand style show

Inserts for square grooving
Pastilhas para torneamento quadrado
Plaquetas para torneado quadrado

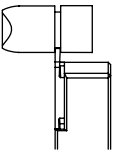
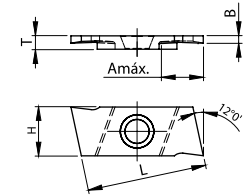

Grooving

(1) Geometry code	(2) Grade code		PVD								Dimensions (mm) Dimensões (mm) Dimensiones (mm)						Cutting conditions Condições de corte Condiciones de corte			
			P				M				B	L	T	H	Amáx.	V°	Ømáx.	fn (mm/r)	Min.	Max.
			G1	G4	G4	P8	G4	P8	G4	P8										
1130441	SAL25G050R-GS	SAL25G050R-GS	☺	☺	☺	☺	☺	☺	☺	0,50	1700	2,00	7,00	2,50	-	-	0,04	0,02	0,06	
1130475	SAL25G070R-GS	SAL25G070R-GS	☺	☺	☺	☺	☺	☺	☺	0,70	1700	2,00	7,00	2,50	-	-	0,05	0,02	0,08	
1130477	SAL25G080R-GS	SAL25G080R-GS	☺	☺	☺	☺	☺	☺	☺	0,80	1700	2,00	7,00	2,50	-	-	0,05	0,02	0,09	
1130479	SAL25G090R-GS	SAL25G090R-GS	☺	☺	☺	☺	☺	☺	☺	0,90	1700	2,00	7,00	2,50	-	-	0,06	0,02	0,10	
1130488	SAL60G110R-GS	SAL60G110R-GS	☺	☺	☺	☺	☺	☺	☺	1,10	1700	2,00	7,00	6,00	-	-	0,06	0,02	0,11	
1130490	SAL60G130R-GS	SAL60G130R-GS	☺	☺	☺	☺	☺	☺	☺	1,30	1700	2,00	7,00	6,00	-	-	0,07	0,02	0,12	
1130442	SAL60G160R-GS	SAL60G160R-GS	☺	☺	☺	☺	☺	☺	☺	1,60	1700	2,00	7,00	6,00	-	-	0,07	0,02	0,13	
1130495	SAL60G185R-GS	SAL60G185R-GS	☺	☺	☺	☺	☺	☺	☺	1,85	1700	2,00	7,00	6,00	-	-	0,08	0,02	0,14	
1130473	SAL25G050L-GS	SAL25G050L-GS	☺	☺	☺	☺	☺	☺	☺	0,50	1700	2,00	7,00	2,50	-	-	0,04	0,02	0,06	
1130474	SAL25G070L-GS	SAL25G070L-GS	☺	☺	☺	☺	☺	☺	☺	0,70	1700	2,00	7,00	2,50	-	-	0,05	0,02	0,08	
1130476	SAL25G080L-GS	SAL25G080L-GS	☺	☺	☺	☺	☺	☺	☺	0,80	1700	2,00	7,00	2,50	-	-	0,05	0,02	0,09	
1130478	SAL25G090L-GS	SAL25G090L-GS	☺	☺	☺	☺	☺	☺	☺	0,90	1700	2,00	7,00	2,50	-	-	0,06	0,02	0,10	
1130487	SAL60G110L-GS	SAL60G110L-GS	☺	☺	☺	☺	☺	☺	☺	1,10	1700	2,00	7,00	6,00	-	-	0,06	0,02	0,11	
1130489	SAL60G130L-GS	SAL60G130L-GS	☺	☺	☺	☺	☺	☺	☺	1,30	1700	2,00	7,00	6,00	-	-	0,07	0,02	0,12	
1130493	SAL60G160L-GS	SAL60G160L-GS	☺	☺	☺	☺	☺	☺	☺	1,60	1700	2,00	7,00	6,00	-	-	0,07	0,02	0,13	
1130494	SAL60G185L-GS	SAL60G185L-GS	☺	☺	☺	☺	☺	☺	☺	1,85	1700	2,00	7,00	6,00	-	-	0,08	0,02	0,14	

☺ Stock item | Produto de stock | Itens de stock

☺ Available under request with delivery time 4 weeks
Disponível sobre consulta com prazo de entrega de 4 semanas
Disponible bajo consulta, con fecha de entrega en 4 semanas

Order code = (1) Geometry code + (2) Grade code

GR SERIES | Inserts | Pastilhas | Plaquetas

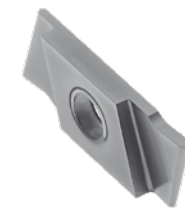

Right hand style show

For round grooving
Para torneamento redondo
Para torneado redondo

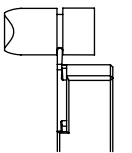
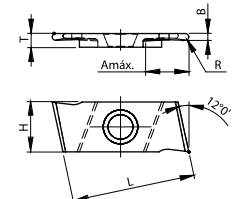

Grooving

(1) Geometry code	(2) Grade code		PVD								Dimensions (mm) Dimensões (mm) Dimensiones (mm)						Cutting conditions Condições de corte Condiciones de corte			
			P				M				B	L	T	H	Amáx.	V°	Ømáx.	fn (mm/r)	Min.	Max.
			G1	G4	G4	P8	G4	P8	G4	P8										
1130443	SAL60G100R-GR	SAL60G100R-GR	☺	☺	☺	☺	☺	☺	☺	1,00	1700	2,00	7,00	6,00	-	-	0,06	0,02	0,10	
1130492	SAL60G150R-GR	SAL60G150R-GR	☺	☺	☺	☺	☺	☺	☺	1,50	1700	2,00	7,00	6,00	-	-	0,08	0,02	0,12	
1130497	SAL60G200R-GR	SAL60G200R-GR	☺	☺	☺	☺	☺	☺	☺	2,00	1700	2,00	7,00	6,00	-	-	0,08	0,03	0,14	
1130486	SAL60G100L-GR	SAL60G100L-GR	☺	☺	☺	☺	☺	☺	☺	1,00	1700	2,00	7,00	6,00	-	-	0,06	0,02	0,10	
1130491	SAL60G150L-GR	SAL60G150L-GR	☺	☺	☺	☺	☺	☺	☺	1,50	1700	2,00	7,00	6,00	-	-	0,08	0,02	0,12	
1130496	SAL60G200L-GR	SAL60G200L-GR	☺	☺	☺	☺	☺	☺	☺	2,00	1700	2,00	7,00	6,00	-	-	0,08	0,03	0,14	

☺ Stock item | Produto de stock | Itens de stock

☺ Available under request with delivery time 4 weeks
Disponível sobre consulta com prazo de entrega de 4 semanas
Disponible bajo consulta, con fecha de entrega en 4 semanas

Order code = (1) Geometry code + (2) Grade code

P(P00) SERIES | Inserts | Pastilhas | Plaquetas

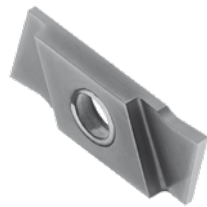

Without front angle
Sem ângulo frontal
Sin ángulo frontal

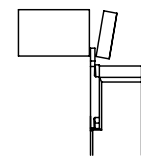
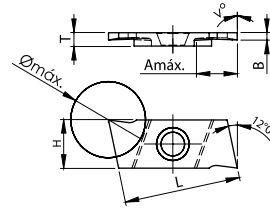

Parting off

(1) Geometry code	(2) Grade code		PVD								Dimensions (mm) Dimensões (mm) Dimensiones (mm)						Cutting conditions Condições de corte Condiciones de corte			
			P M K S								B	L	T	H	Amáx.	V°	Ømáx.	fn (mm/r)	Min.	Max.
			G1	G4	G4	P8	G4	P8	G4	P8										
1130444	SAL11P100RN-P00	SAL11P100RN-P00	○	⊗	⊗	○	⊗	○	⊗	○	1,00	17,00	2,00	7,00	6,00	0	11,00	0,06	0,02	0,10
1130462	SAL11P150RN-P00	SAL11P150RN-P00	○	⊗	⊗	○	⊗	○	⊗	○	1,50	17,00	2,00	7,00	6,00	0	11,00	0,08	0,02	0,12
1130468	SAL13P200RN-P00	SAL13P200RN-P00	○	⊗	⊗	○	⊗	○	⊗	○	2,00	17,00	2,00	7,00	6,00	0	13,00	0,08	0,03	0,14
1130456	SAL11P100LN-P00	SAL11P100LN-P00	○	⊗	⊗	○	⊗	○	⊗	○	1,00	17,00	2,00	7,00	6,00	0	11,00	0,06	0,02	0,10
1130459	SAL11P150LN-P00	SAL11P150LN-P00	○	⊗	⊗	○	⊗	○	⊗	○	1,50	17,00	2,00	7,00	6,00	0	11,00	0,08	0,02	0,12
1130465	SAL13P200LN-P00	SAL13P200LN-P00	○	⊗	⊗	○	⊗	○	⊗	○	2,00	17,00	2,00	7,00	6,00	0	13,00	0,08	0,03	0,14

⊗ Stock item | Produto de stock | Itens de stock

○ Available under request with delivery time 4 weeks
Disponível sobre consulta com prazo de entrega de 4 semanas
Disponible bajo consulta, con fecha de entrega en 4 semanas

Order code = (1) Geometry code + (2) Grade code

P(P07) SERIES | Inserts | Pastilhas | Plaquetas

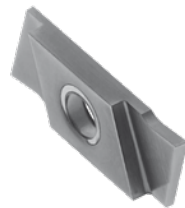

Front angle 7°
Ângulo frontal de 7°
Ángulo frontal de 7°

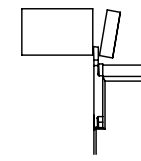
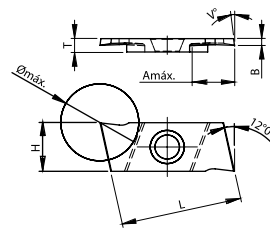

Parting off

(1) Geometry code	(2) Grade code		PVD								Dimensions (mm) Dimensões (mm) Dimensiones (mm)						Cutting conditions Condições de corte Condiciones de corte			
			P M K S								B	L	T	H	Amáx.	V°	Ømáx.	fn (mm/r)	Min.	Max.
			G1	G4	G4	P8	G4	P8	G4	P8										
1130445	SAL11P100RR-P07	SAL11P100RR-P07	○	⊗	⊗	○	⊗	○	⊗	○	1,00	17,00	2,00	7,00	6,00	7	11,00	0,05	0,02	0,08
1130446	SAL11P100RL-P07	SAL11P100RL-P07	○	⊗	⊗	○	⊗	○	⊗	○	1,00	17,00	2,00	7,00	6,00	7	11,00	0,05	0,02	0,08
1130463	SAL11P150RR-P07	SAL11P150RR-P07	○	⊗	⊗	○	⊗	○	⊗	○	1,50	17,00	2,00	7,00	6,00	7	11,00	0,06	0,02	0,10
1130461	SAL11P150RL-P07	SAL11P150RL-P07	○	⊗	⊗	○	⊗	○	⊗	○	1,50	17,00	2,00	7,00	6,00	7	11,00	0,06	0,02	0,10
1130469	SAL13P200RR-P07	SAL13P200RR-P07	○	⊗	⊗	○	⊗	○	⊗	○	2,00	17,00	2,00	7,00	6,00	7	13,00	0,06	0,03	0,12
1130467	SAL13P200RL-P07	SAL13P200RL-P07	○	⊗	⊗	○	⊗	○	⊗	○	2,00	17,00	2,00	7,00	6,00	7	13,00	0,06	0,03	0,12
1130457	SAL11P100LR-P07	SAL11P100LR-P07	○	⊗	⊗	○	⊗	○	⊗	○	1,00	17,00	2,00	7,00	6,00	7	11,00	0,05	0,02	0,08
1130455	SAL11P100LL-P07	SAL11P100LL-P07	○	⊗	⊗	○	⊗	○	⊗	○	1,00	17,00	2,00	7,00	6,00	7	11,00	0,05	0,02	0,08
1130460	SAL11P150LR-P07	SAL11P150LR-P07	○	⊗	⊗	○	⊗	○	⊗	○	1,50	17,00	2,00	7,00	6,00	7	11,00	0,06	0,02	0,10
1130458	SAL11P150LL-P07	SAL11P150LL-P07	○	⊗	⊗	○	⊗	○	⊗	○	1,50	17,00	2,00	7,00	6,00	7	11,00	0,06	0,02	0,10
1130466	SAL13P200LR-P07	SAL13P200LR-P07	○	⊗	⊗	○	⊗	○	⊗	○	2,00	17,00	2,00	7,00	6,00	7	13,00	0,06	0,03	0,12
1130464	SAL13P200LL-P07	SAL13P200LL-P07	○	⊗	⊗	○	⊗	○	⊗	○	2,00	17,00	2,00	7,00	6,00	7	13,00	0,06	0,03	0,12

⊗ Stock item | Produto de stock | Itens de stock

○ Available under request with delivery time 4 weeks
Disponível sobre consulta com prazo de entrega de 4 semanas
Disponible bajo consulta, con fecha de entrega en 4 semanas

Order code = (1) Geometry code + (2) Grade code

PT SERIES | Inserts | Pastilhas | Plaquetas



For partial profile Threading
Para perfil parcial de roscagem
Para perfil parcial de roscado

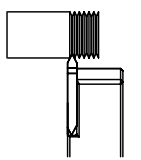
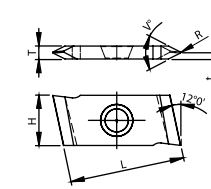

Threading

(1) Geometry code	(2) Grade code		PVD								Dimensions (mm) Dimensões (mm) Dimensiones (mm)						Cutting conditions Condições de corte Condiciones de corte			
			P M K S								B	L	T	H	Amáx.	V°	Ømáx.	fn (mm/r)	Min.	Max.
			G1	G4	G4	P8	G4	P8	G4	P8										
1130472	SAL100H012R55-PT	SAL100H012R55-PT	○	⊗	⊗	○	⊗	○	⊗	○	1,00	17,00	2,00	7,00	0,12	55	-	0,80	0,20	2,00
1130447	SAL100H012R60-PT	SAL100H012R60-PT	○	⊗	⊗	○	⊗	○	⊗	○	1,00	17,00	2,00	7,00	0,12	60	-	0,80	0,20	2,00
1130470	SAL100H012L55-PT	SAL100H012L55-PT	○	⊗	⊗	○	⊗	○	⊗	○	1,00	17,00	2,00	7,00	0,12	55	-	0,80	0,20	2,00
1130471	SAL100H012L60-PT	SAL100H012L60-PT	○	⊗	⊗	○	⊗	○	⊗	○	1,00	17,00	2,00	7,00	0,12	60	-	0,80	0,20	2,00

⊗ Stock item | Produto de stock | Itens de stock

○ Available under request with delivery time 4 weeks
Disponível sobre consulta com prazo de entrega de 4 semanas
Disponible bajo consulta, con fecha de entrega en 4 semanas

Order code = (1) Geometry code + (2) Grade code

TP SERIES | Inserts | Pastilhas | Plaquetas

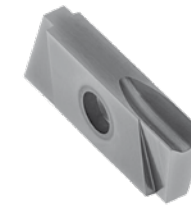

For turning
Para torneamento
Para torneado

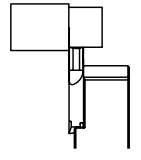
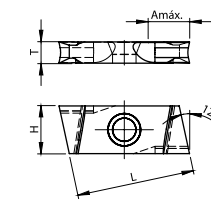

Turning

(1) Geometry code	(2) Grade code		PVD								Dimensions (mm) Dimensões (mm) Dimensiones (mm)						Cutting conditions Condições de corte Condiciones de corte			
			P M K S								B	L	T	H	Amáx.	V°	Ømáx.	fn (mm/r)	Min.	Max.
			G1	G4	G4	P8	G4	P8	G4	P8										
1130501	SAL60T300R-TP	SAL60T300R-TP	○	⊗	⊗	○	⊗	○	⊗	○	-	17,00	3,17	7,00	6,00	-	-	0,08	0,02	0,12
1130499	SAL60T300L-TP	SAL60T300L-TP	○	⊗	⊗	○	⊗	○	⊗	○	-	17,00	3,17	7,00	6,00	-	-	0,08	0,02	0,12

⊗ Stock item | Produto de stock | Itens de stock

○ Available under request with delivery time 4 weeks
Disponível sobre consulta com prazo de entrega de 4 semanas
Disponible bajo consulta, con fecha de entrega en 4 semanas

Order code = (1) Geometry code + (2) Grade code

BLANKS FOR GRINDING | Blanks para personalizar | Blanks para personalizar

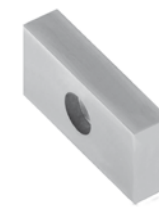

Right hand style show

Inserts blanks "do it yourself" grinding are available allowing modifications of the insert for any machining operation.

As pastilhas de blank "faça você mesmo" permitem a personalização da pastilha para qualquer operação de maquinação.

Las plaquetas de blank "haga usted mismo" permiten la personalización de la plaqueta para cualquiera operación de maquinação.

(1) Geometry code	(2) Grade code		Uncoated			Dimensions (mm) Dimensões (mm) Dimensiones (mm)						
			10	12	14	B	L	T	H	Amáx.	V°	Ømáx.
			PH0910	PH0920	PH0135							
1130440	BLANK SALR 17x7x2		⊗	⊗	⊗	-	17,50	2,00	7,50	-	-	-
1130504	BLANK SALR 17x7x3,17		⊗	⊗	⊗	-	17,50	3,17	7,50	-	-	-
1130453	BLANK SALL 17x7x2		⊗	⊗	⊗	-	17,50	2,00	7,50	-	-	-
1130505	BLANK SALL 17x7x3,17		⊗	⊗	⊗	-	17,50	3,17	7,50	-	-	-

⊗ Stock item | Produto de stock | Itens de stock

○ Available under request | Disponível sobre consulta | Disponible bajo consulta

Order code = (1) Geometry code + (2) Grade code

GROOVING | Canais | Ranurado



- High precision
- Close tolerances
- Wide variety of insert widths

GS

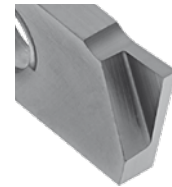

Square grooving

GR

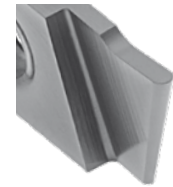

Round grooving

Recommended cutting conditions

P	M	K	S
60-200	60-180	60-150	20-50

Recommended grade PH7920, (Vc) m/min.

Grade PH7910 and PH7135

Available under request (4 weeks delivery time)

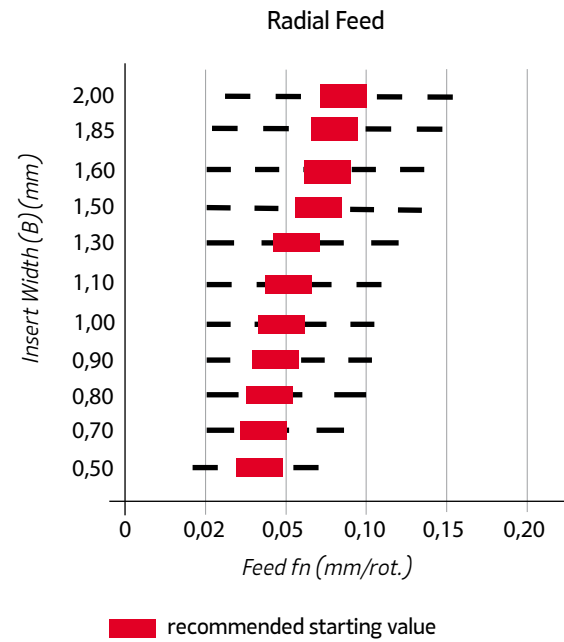

PARTING OFF | Corte | Tronzado

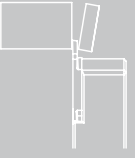

- When parting off with a sub-spindle, it is more productive to use a straight cutting edge. This is a more stable parting method and will generate the best surface finish.
- When parting off without a sub-spindle, we recommend you use an insert with a maximum 7° front angle to minimize the risk of burr and pips on the component.
- When parting off with 7° front angled inserts, we recommend reducing the feed rate by approximately 30%.

P00

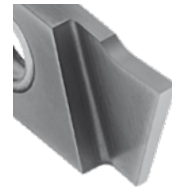

0° Relief angle

P07

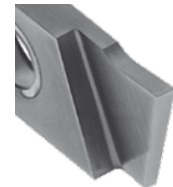

7° Relief angle

Recommended cutting conditions

P	M	K	S
60-200	60-180	60-150	20-50

Recommended grade PH7920, (Vc) m/min.

Grade PH7910 and PH7135

Available under request (4 weeks delivery time)

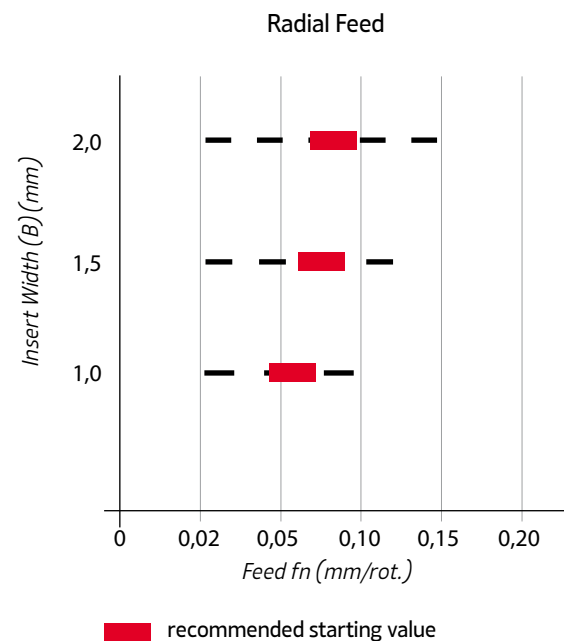

THREADING | Rosagem | Roscado



Two types of threading:

- Partial profile 55°
- Partial profile 60°

PT

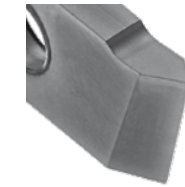

Partial profile

Recommended cutting conditions

P	M	K	S
60-200	60-180	60-150	20-50

Recommended grade PH7920, (Vc) m/min.

Grade PH7910 and PH7135

Available under request (4 weeks delivery time)

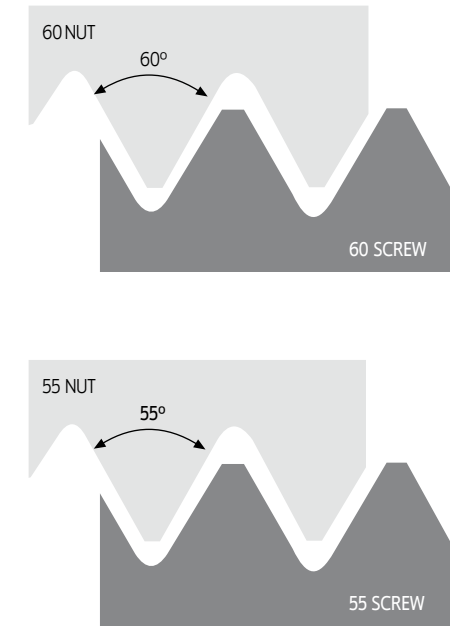

TURNING | Torneamento | Torneado

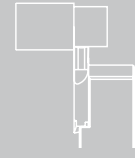

- Insert for turning
- Maximum deep of cut is 3,00 mm
- Too low cutting speed will result in inadequate tool life and it is advisable to follow cutting speed recommendations.

TP

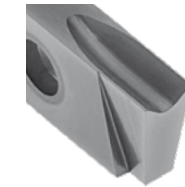

Turning steel

Recommended cutting conditions

P	M	K	S
60-200	60-180	60-150	20-50

Recommended grade PH7920, (Vc) m/min.

Grade PH7910 and PH7135

Available under request (4 weeks delivery time)

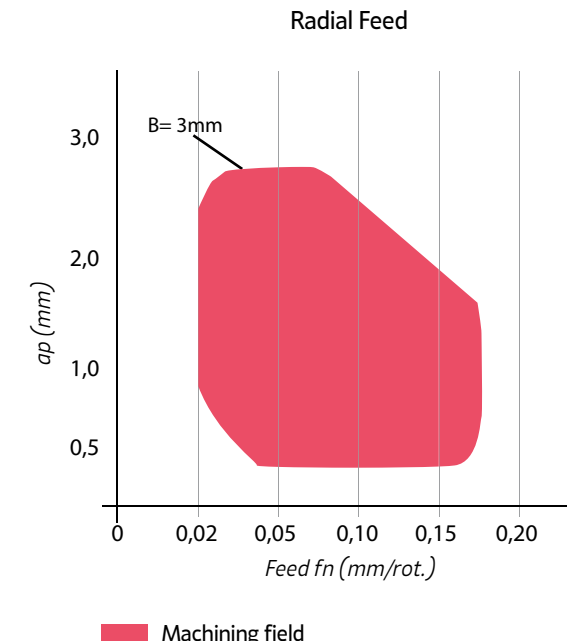

TEST REPORT 01

P00

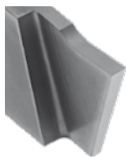

0° Front angle

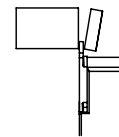

Parting off

Toolholder
SALHER 1212 M07

Insert
SAL11P100RN - P00

Grade
PH7920

20% productivity improvement

Number of pieces
12 000

Toolholder
Competitor Equivalent product

Insert
Competitor Equivalent product

Grade
Competitor Equivalent product

Number of pieces
10 000



Work material: AISI 316

Cutting speed: Vc (m/min)	100
Feed per tooth: fn (mm/r)	0,08
Diameter (mm)	10
Machining method	Parting off
Coolant	Yes

TEST REPORT 02

GS

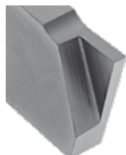

Insert for square grooving

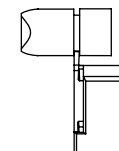

Grooving

Toolholder
SALHER 1616 M07

Insert
SAL25G080R - GS

Grade
PH7920

25% productivity improvement

Number of pieces
10 000

Toolholder
Competitor Equivalent product

Insert
Competitor Equivalent product

Grade
Competitor Equivalent product

Number of pieces
8 000



Work material: 34CrNiMo6

Cutting speed: Vc (m/min)	120
Feed per tooth: fn (mm/r)	0,05
Diameter (mm)	8
Machining method	Grooving
Coolant	Yes

(19)

FYMKT_26_ED000_REV02